

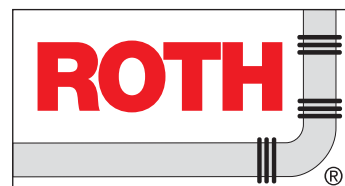

Stainless

steel expansion joints

www.roth-kompensatoren.de



ООО «ТИ-СИСТЕМС» ИНЖИНИРИНГ И ПОСТАВКА ТЕХНОЛОГИЧЕСКОГО ОБОРУДОВАНИЯ

Интернет: www.tisys.ru www.tisys.kz www.tisys.by www.tesec.ru www.ти-системс.рф

Телефоны: +7 (495) 7774788, 7489626, 5007155, 54 Эл. почта: info@tisys.ru info@tisys.kz info@tisys.by



- ▶ Introduction | 3.1
- ▶ Design and Construction | 3.2
- ▶ Materials and Thermal Expansion | 3.2
- ▶ Constructive Types | 3.4
- ▶ Axial Expansion Joints | 3.5
 - Constructive Types | 3.6
 - Standard Program H-Line PN16 / PN25 | 3.7
 - Standard Program H-Line PN16 (threaded) | 3.8
 - Standard Program R-Line PN1 / PN2,5 / PN6 | 3.9
 - Typical Cases Examples | 3.10
- ▶ Lateral Expansion Joints | 3.11
 - Universal Expansion Joints | 3.11
 - Constructive Types | 3.12
 - Standard Program R-Line PN1 / PN2,5 / PN6 | 3.13
 - Typical Cases Examples | 3.14
- ▶ Angular Expansion Joints | 3.15
 - Constructive Types | 3.16
 - Typical Cases Examples | 3.17
- ▶ Special Design Expansion Joints | 3.18
 - Rectangular Expansion Joints | 3.18
 - LENS Expansion Joints | 3.19
 - Pressure Balanced Expansion Joints | 3.19
- ▶ General Notes on Installation | 3.21



Stainless steel expansion joints



Introduction

Stainless steel expansion joints are essential elements of modern pipe technology. They offer the perfect solution in absorbing expansion caused by temperature changes in pipe systems. Furthermore, they are able to compensate any vibrations which may occur in pumping systems, motors, compressors, or turbines. The basic advantages to be gained from using expansion joints are:

- ▶ Small space required for installation;
- ▶ Absorption of movements in multiple directions due to their inherent flexibility;
- ▶ They require almost no maintenance;
- ▶ They reduce load and temperature loss to a minimum.

Axial, lateral or angular movements and vibration can be absorbed, according to the each individual situation. For choosing the most appropriate type of expansion joint, our technical department will be at your disposal for consultation at any time.

The characteristics of an expansion joint are based on the flexibility of its bellow. This flexibility results from the bellow's geometrical shape and the number of convolutions. Also, the thickness of each ply and the materials used for construction play an important role in defining the characteristics of the expansion joint.

ROTH stainless steel expansion joints can be made of single-ply or multi-ply bellows depending on the requirements of each given application. We recommend to provide us with all necessary data, enabling us to take into account values of movement, pressure, temperature and other environment variables and thus to find the optimum technical design and the best cost-saving solution for your application.

▶ Design and Construction

ROTH – expansion joints are designed, manufactured and approved in accordance to: EJMA-Standards (EXPANSION JOINTS MANUFACTURERS ASSOCIATION INC.), APPENDIX BB OF SECTION VIII OF ASME – CODE “PRESSURE VESSEL AND HEAT EXCHANGER EXPANSION JOINTS“

▶ Materials and Thermal Expansion

The most commonly used materials for bellows, connecting components and tie-rod systems are shown in the following table. Other materials are also available on request.

Part	Material No.	Short name	DIN EN	AISI	ASTM
Bellows and internal sleeves	1.4301	X5CrNi18-10	10088	304	SA 240 TP 304
	1.4306	X2CrNi19-11	10088	304L	SA 240 TP 304 L
	1.4310	X10CrNi18-8	10088	301	–
	1.4401	X5CrNiMo17-12-2	10088	316	SA 240 TP 316
	1.4404	X2CrNiMo17-12-2	10088	316L	SA 240 TP 316L
	1.4435	X2CrNiMo18-14-3	10088	–	–
	1.4436	X3CrNiMo17-13-3	10088	–	–
	1.4462	X2CrNiMoN-22-5	10888	–	–
1.4541	X6CrNiTi18-10	10088	321	SA 240 TP 321	
Connecting components (stainless steel)	1.4571	X6CrNiMoTi17-12-2	10088	316Ti	SA 240 TP 316Ti
	1.4828	X15CrNiSi20-12	10095	309	SA 240 TP 309
	1.4841	X15CrNiSi25-20	10095	310	SA 240 TP 310
	1.4893	X8CrNiSiN21-11	–	–	S 30815
Connecting components (carbon steel)	1.0037	S235JR	10025	–	A 570 Gr 36
	1.0305	St35.8	17175	–	A 106-65 Gr A
	1.0308	St35	17175	–	A 53-65 Gr A
	1.0345	P235GH	10028	–	A 515 Gr 65,55
	1.0425	P265GH	10028	–	A 515-65 Gr 60
	1.0481	P295GH	10028	–	A 515 Gr 70
	1.0570	S355J2G3	10025	–	–
Tie-rod systems	1.5415	16Mo3	10028	–	A 204 Gr A
	1.7335	13CrMo4-5	10028	–	A 182-F11, F12

Please use the following diagrams in order to identify the resulting values for thermal expansion at a specific temperature and for a given category of material. For other materials please contact our technical department.

Diagrams for Thermal Expansion

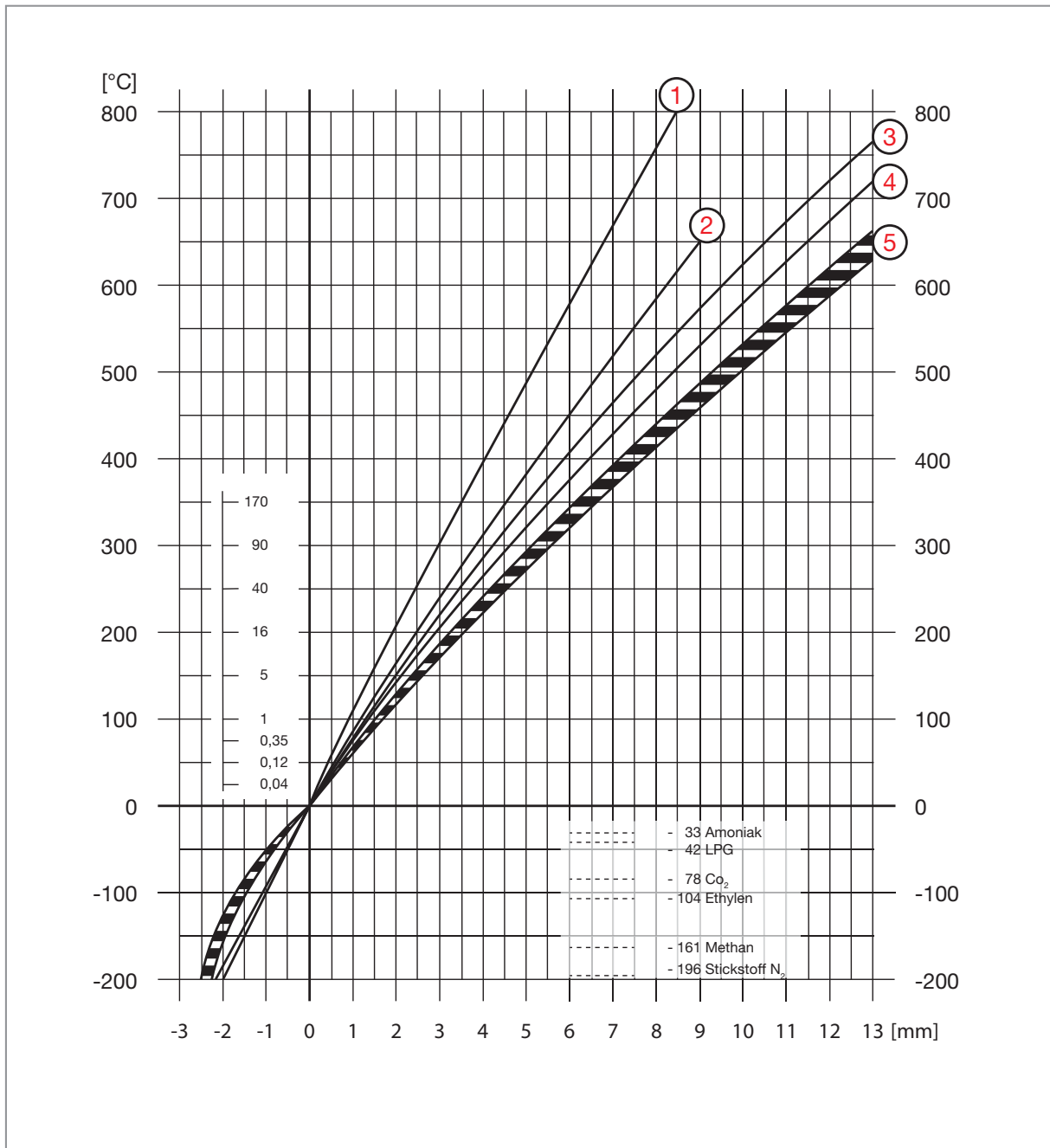

Titanium	①	3.7024					
Carbon steel	②	St. 37.2 1.0114	St. 35.8 1.0305	C. 22.N 1.0402	H-II 1.0425	15Mo3 1.5415	13CrMo44 1.7335
Inconel	③	2.4816		2.4856			
Monel/ Incoloy	④	2.4360		1.4876			2.4858
Stainless steel	⑤	1.4301	1.4404	1.4435	1.4541	1.4571	1.4539

▶ Axial Expansion Joints

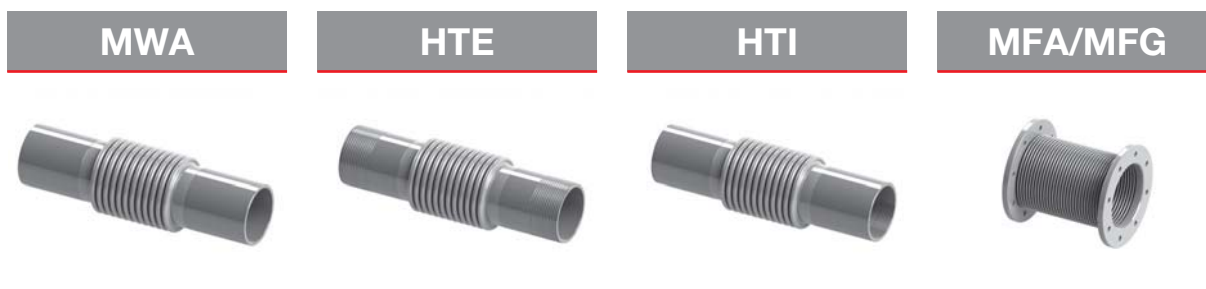

▶ Lateral Expansion Joints

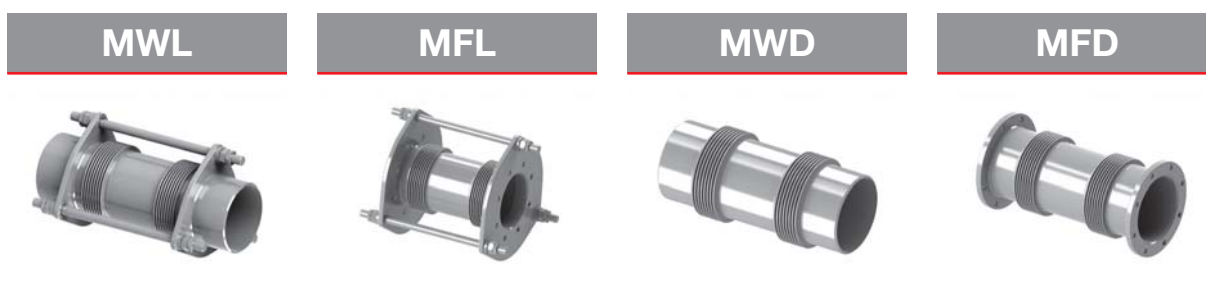

▶ Angular Expansion Joints

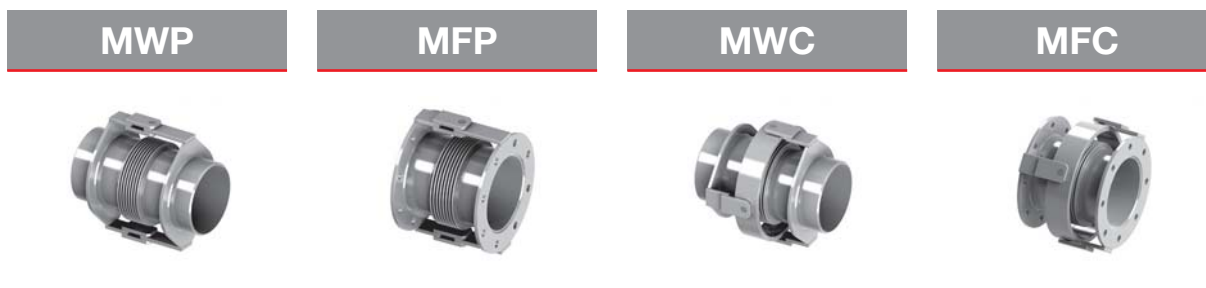

▶ Special Design Expansion Joints

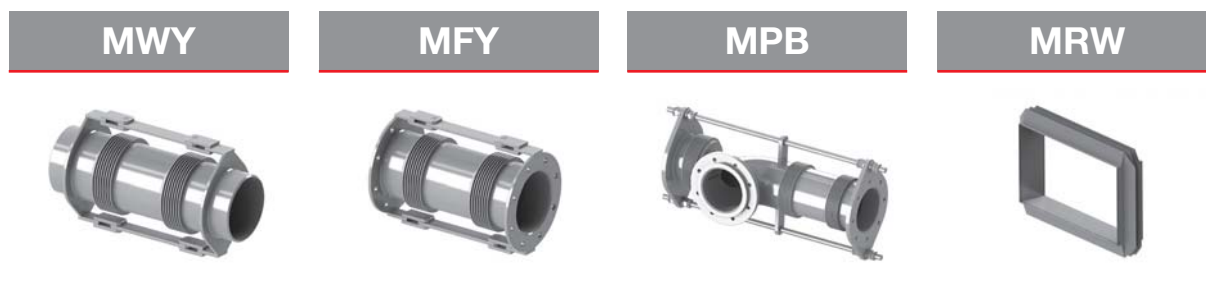

▶ Axial Expansion Joints

The most common and simple type of compensation is provided by axial expansion joints. These counteract linear changes in the longitudinal direction of a pipeline, but are usually also able to absorb some angular movements and vibrations.

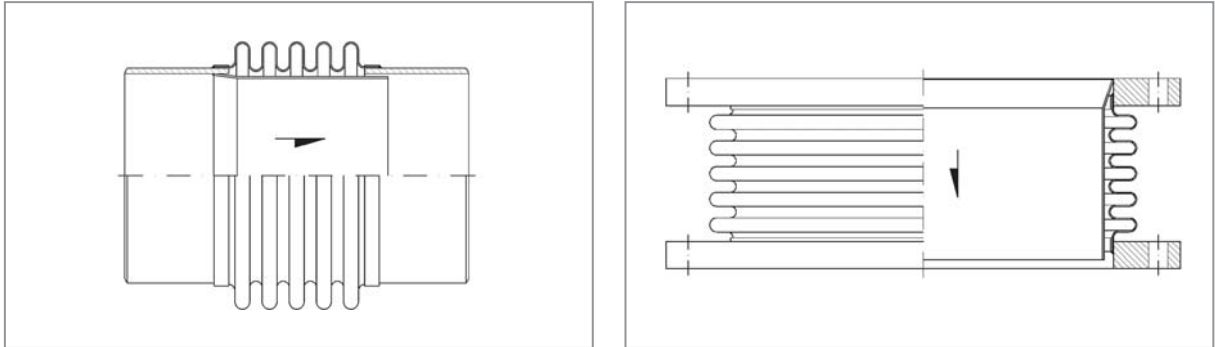

Unrestrained axial expansion joints do not restrain pressure thrust so adequate anchors and guides must be provided and they can be used only in piping systems that incorporate correctly designed anchors and pipe alignment guides.

As illustrated below, axial expansion joints necessitates properly dimensioned and arranged fixed points and guides.

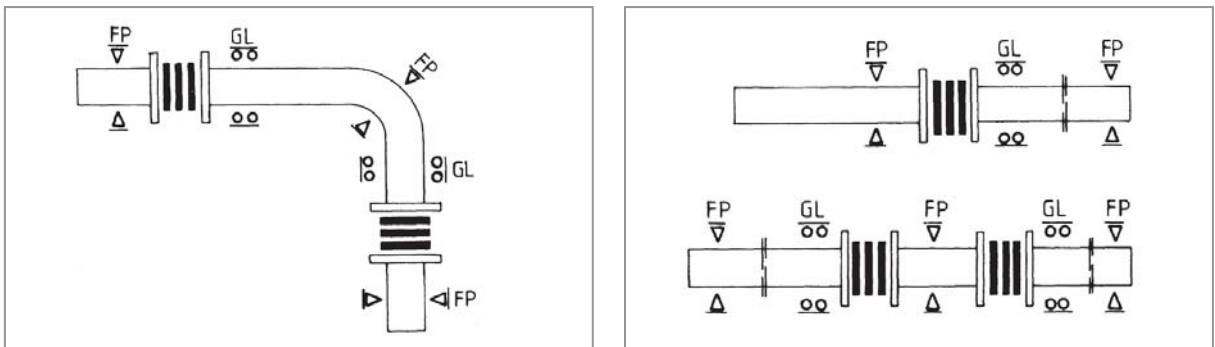

FP = fixed point, GL = guide

In the case of axial expansion joints, the load acting on the required fixed points derives from the pressure and inherent resistance of the expansion joint as well as the pipe frictional forces.

The thrust is the product of the effective cross-sectional area and the operating pressure, the inherent resistance is the spring rate value, and the pipe frictional forces depend on the pipe bearing, pipeline weight, and pipe friction coefficient.

In order to assure proper operation for any axial expansion joint please take in consideration the following notes regarding basic installation:

- ▶ Only one expansion joint between two fixed points;
- ▶ Locate fixed points and guides as close to the expansion joint as possible;
- ▶ The pipelines must be exactly aligned;
- ▶ The expansion joint must not be subjected to torsional stress;
- ▶ Only low-frequency vibration loads are permissible;
- ▶ Where welding is required in assembly, the bellows must be protected from sparks;
- ▶ Protect bellows, supports, and pipe guides against soiling and damage.

Constructive Types

Axial expansion joints are based on a single bellow construction. Available with weld-ends, flanges or thread-ends and with or without tie-rods. The couplings are made out of steel or stainless steel.

MWA/HWA

Axial Expansion Joint
weld-ends,
inner sleeves
on request.



MFA/MFG

Axial Expansion Joint
with fixed or
swivel flanges.



Type	Series	Press. thrust restraint	Movements		
			Axial	Lateral	Angular
Single Unrestrained**	MWA / HWA MFA / MFG HFA / HFG RFA / RFG	no**	yes	Single-Plane	Single-Plane
				yes*	yes*
				Multi-Plane	Multi-Plane
				yes*	yes*

HTE

Axial Expansion Joint
with external
thread.



HTI

Axial Expansion Joint
with internal
thread.



Type	Series	Press. thrust restraint	Movements		
			Axial	Lateral	Angular
Single Unrestrained**	HTE HTI	no**	yes	Single-Plane	Single-Plane
				yes*	yes*
				Multi-Plane	Multi-Plane
				yes*	yes*

* Limited use.

** Constructions with tie-rods systems are available on request. Pressure thrust restraint can be achieved.

Standard Program H-Line PN16 / PN25

Our standard H-Line program for axial stainless steel expansion joints includes weld-ended HWA and flanged HFA/G items for a nominal pressure up to 25 bar, within a size-range of DN15-DN250.



HWA

Axial Expansion Joint
with weld-ends, pipes acc.to ISO, DIN or others, inner sleeves on request.



HFA/HFG

Axial Expansion Joint
with fixed flanges (HFA) or swivel flanges (HFG), inner sleeve on request.

Nominal diameter DN	Axial movement [mm]	Spring rate [N/mm]	Overall length [mm]		Approx. weight [kg]	
			HWA/HWAI	HFA / HFG	HWA/HWAI	HFA / HFG
15	± 12,0	29	175	100	0,1	1,3
20	± 12,0	29	175	100	0,2	1,6
25	± 15,0	65	185	105	0,3	2,2
32	± 15,0	60	185	120	0,4	3,5
40	± 15,0	72	190	125	0,5	3,9
50	± 23,0	82	205 220*	150	0,8	4,7
65	± 23,0	72	230 240*	155	1,2	5,9
80	± 23,0	91	230 240*	165	1,7	8,0
100	± 23,0	79	230 250*	170	2,2	8,7
125	± 23,0	119	270 280*	185	3,3	10,9
150	± 33,0	162	270 315*	205	4,3	12,7
200	± 35,0	149	300 355*	235	6,5	18,2
250	± 35,0	153	300 355*	240	8,0	12,7

* HWA type with inner sleeve.

Standard Program H-Line PN16 (threaded)

Our standard H-Line program for axial stainless steel expansion joints is extended by two constructive types featuring threaded ends. These are available either with external threads (HTE) or either with internal threads (HTI), both for a nominal pressure of 16 bar. Thread-ends are available in all existing international standards and can be made out of carbon steel or stainless steel.



Nominal diameter DN / R"	Capable movement			Spring rate [N/mm]	Cross-section [mm]	Overall length [mm]	Outer - Ø [mm]
	axial [mm]	lateral [mm]	angular [z °]				
15 1/2"	± 12,0	± 5	± 30°	29	7	170	36
20 3/4"	± 12,0	± 5	± 30°	29	7	170	36
25 1"	± 15,0	± 8	± 30°	65	10	170	42
32 1 1/4"	± 15,0	± 12	± 30°	60	14,5	185	50
40 1 1/2"	± 15,0	± 12	± 30°	72	22	200	60
50 2"	± 23,0	± 11	± 25°	82	34	225	75
65 2 1/2"	± 23,0	± 11	± 25°	72	50	260	90
80 3"	± 23,0	± 10	± 20°	91	74	275	110
100 4"	± 23,0	± 10	± 20°	79	111	310	133

* Other sizes available on request. Subject to alteration.

Stainless steel expansion joints with threaded ends have a higher bellow flexibility that makes them capable to compensate movements in any planes (axial, lateral and angular). This feature, beside the threaded coupling make them an ideal solution in application where there is less mounting space at disposal.

Standard Program R-Line PN1 / PN2,5 / PN6

Our standard R-Line program for axial stainless steel expansion joints is designed to offer very competitive items for low-pressure ventilation, exhaust application, etc. These expansion joints are available with flanges (RFA/RFG) or with weld-ends (RWA). The materials used for flanges or weld-ends can be for the couplings can be carbon-steel or stainless steel.



RWA

Axial Expansion Joint
with weld-ends, pipes acc.to ISO, DIN or others, inner sleeves on request.



RFA/ RFG

Axial Expansion Joint
with fixed flanges (RFA) or swivel flanges (RFG), inner sleeve on request.

Nominal diameter DN	Axial movement [mm]	Spring rate [N/mm]	Overall length [mm]		Approx. weight [kg]	
			RWA	RFA / RFG	RWA	RFA / RFG
300	±30	58	280	300	5	20
350	±30	59	280	300	5.7	21
400	±30	79	250	270	6.3	24
450	±30	80	250	270	7.1	26
500	±30	70	260	280	8	29
560	±30	72	260	280	8.8	32
600	±30	72	260	280	12	36
630	±30	74	260	280	12.4	38
700	±30	67	260	280	14	42
800	±30	67	260	280	16	48
900	±30	68	260	280	18	54
1000	±30	104	290	320	27	91
1200	±30	112	290	320	32	110
1400	±30	118	290	320	55	143
1500	±30	122	290	320	58	150
1600	±30	126	290	320	62	162
1700	±30	130	290	320	66	207
1800	±30	134	290	320	70	220
2000	±30	143	290	320	77	250

* Other sizes available on request. Subject to alteration.

Typical Cases Examples

Axial expansion joints cannot withstand thrust from the internal pressure and must therefore always be fitted in between two principal fixed points. Secondary (intermediate) fixed points can also be installed along the pipe segment. Guides are to be used to ensure that there will be no displacements along the pipe line. The following are typical layout examples:

- A. Basic case, expansion joint situated in a straight between two principal fixed points.



- B. HFP's are situated at pipe bends, compensating the straight length in-between as shown in case A.

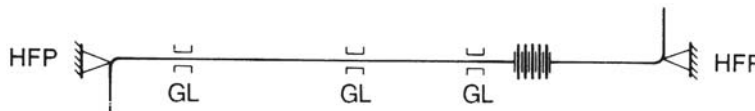

- C. Applies for very long straights; ZFP and two axial expansion joints required, situated between two HFP's.

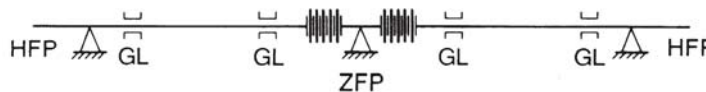

- D. The principal fixed point is located at the intersection of two pipe lengths.

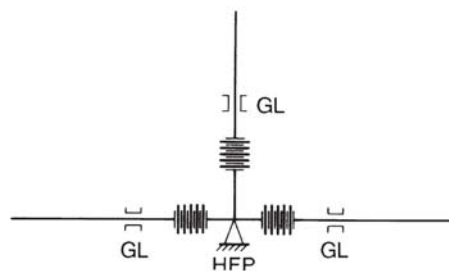

- E. The HFP is located at the meeting point of two pipes of different sections, as a consequence of the different reactional forces.

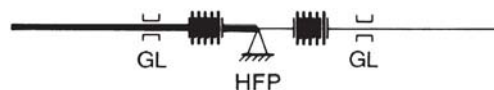

HFP = principal fixed point; ZFP = interm. fixed point; GL = guide.

▶ Lateral Expansion Joints

Lateral expansion joints are designed with tie-rod supports, allowing movements only to the sides; therefore, installation must be executed vertically to the direction of movement of the conduit. Axial expansion can not be absorbed. The most favorable types are those absorbing expansion in a circular plane.

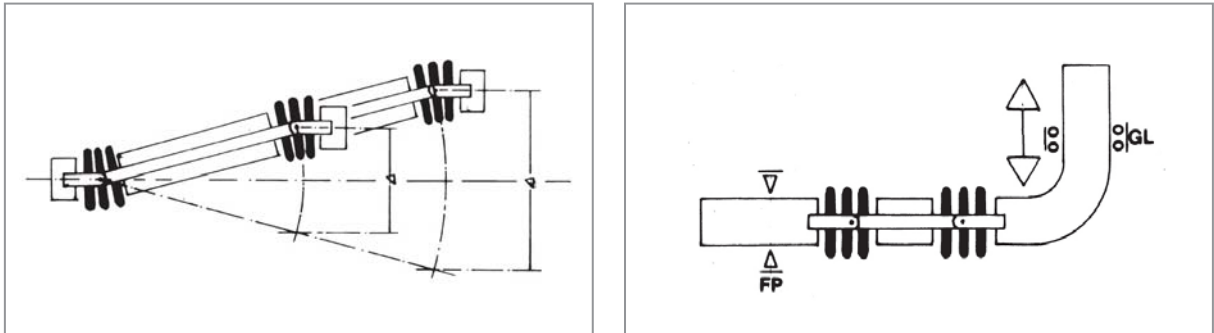

The standard joint construction allows movements in one plane only. The bellows' flexibility as well as the distance between the middle of the bellows are crucial for the value of the permissible movement: the longer the intermediate pipe, the larger the lateral movement.

A lateral expansion joint depicts a complete 2-joint-system. The axial reactional forces caused by the internal pressure are absorbed by these joints, so that the resulting fixed point loads are very low. Large movements can be absorbed by relatively simple pipe constructions.

Important factors are the spring rate and joint frictional forces. Lateral expansion joints with tie-rod supports are also able to absorb vibrations at pumps and compressors, with fixed points assembled directly behind the expansion joints.

A particular case of lateral expansion joint are universal expansion joints. A particular case of lateral expansion joint are universal expansion joints. These items are a special type construction, available both with weld-ends and flanges, that allow multi-plane movement compensation. Universal expansion joints have similar construction as lateral expansion joints with the exception of the tie-rods system.

Universal Expansion Joints

Our universal expansion joints are the special types of our product range: lateral expansion joints without tie-rods, absorbing both lateral and axial movements. They mainly apply for pipe systems with low internal pressure; any reactional forces are to be compensated by the conduit.

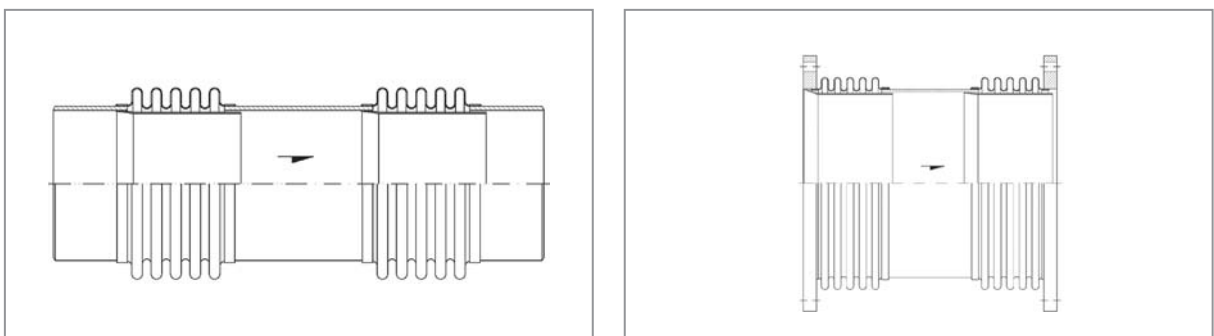

Constructive Types

Lateral Expansion Joints are based on a two in-line bellow construction with an intermediate pipe between. Available with weld-ends or flanges and with or without tie-rods.

MWD

Universal Expansion Joint
with weld-ends and intermediate pipe.



MFD

Universal Expansion joint
with flanges and intermediate pipe.



Type	Series	Press. thrust restraint	Movements		
			Axial	Lateral	Angular
Universal Unrestrained	MWD MFD	no	yes	Single-Plane	Single-Plane
				yes*	yes*
				Multi-Plane	Multi-Plane
				yes*	yes*

MWL

Lateral Expansion Joint
with weld-ends, with tie-rod supports.



MFL

Lateral Expansion Joint
with flanges, with tie-rod supports.



Type	Series	Press. thrust restraint	Movements		
			Axial	Lateral	Angular
Lateral Tied	MWL MFL	yes	no*	Single-Plane	Single-Plane
				yes	no**
				Multi-Plane	Multi-Plane
				yes	no**

* some axial movements may be absorbed with a specific design.

** some angular movement can be absorbed providing 2 tie rods at 180 degrees only.

Standard Program R-Line PN1 / PN2,5 / PN6

Our standard R-Line program for universal stainless steel expansion joints includes unrestrained weld-ended (RWD) and flanged (RFD) items for a nominal pressure of 1 bar or more.



RWD

Universal Expansion Joint
with
weld-ends and
intermediate
pipe.



RFD

Universal Expansion joint
with
flanges and
intermediate
pipe.

Nominal diameter DN	Axial movement [mm]	Lateral movement [mm]	Axial spring rate [N/mm]	Lateral spring rate [N/mm]	Overall length [mm]		Approx. weight [kg]	
					RWD	RFD	RWD	RFD
300	±30	±60	51	6	800	800	15	30
350	±30	±60	60	7	800	800	16	32
400	±30	±60	61	9	800	800	19	37
450	±30	±60	61	9	850	850	23	42
500	±30	±60	58	11	850	850	25	46
560	±30	±60	58	13	850	850	27	50
600	±30	±60	58	16	850	850	38	62
630	±30	±60	44	15	850	850	36	62
700	±30	±60	47	14	950	950	48	76
800	±30	±60	42	14	1000	1000	55	87
900	±30	±60	46	18	1000	1000	62	98
1000	±30	±60	61	32	1100	1100	95	159
1200	±30	±60	63	41	1100	1100	110	188
1400	±30	±60	65	55	1100	1100	177	265
1500	±30	±60	58	44	1200	1200	232	324
1600	±30	±60	61	50	1200	1200	248	350
1700	±30	±60	64	57	1200	1200	265	406
1800	±30	±60	67	63	1200	1200	280	430
2000	±30	±60	58	44	1300	1300	350	523

*Other sizes available on request. Subject to alteration.

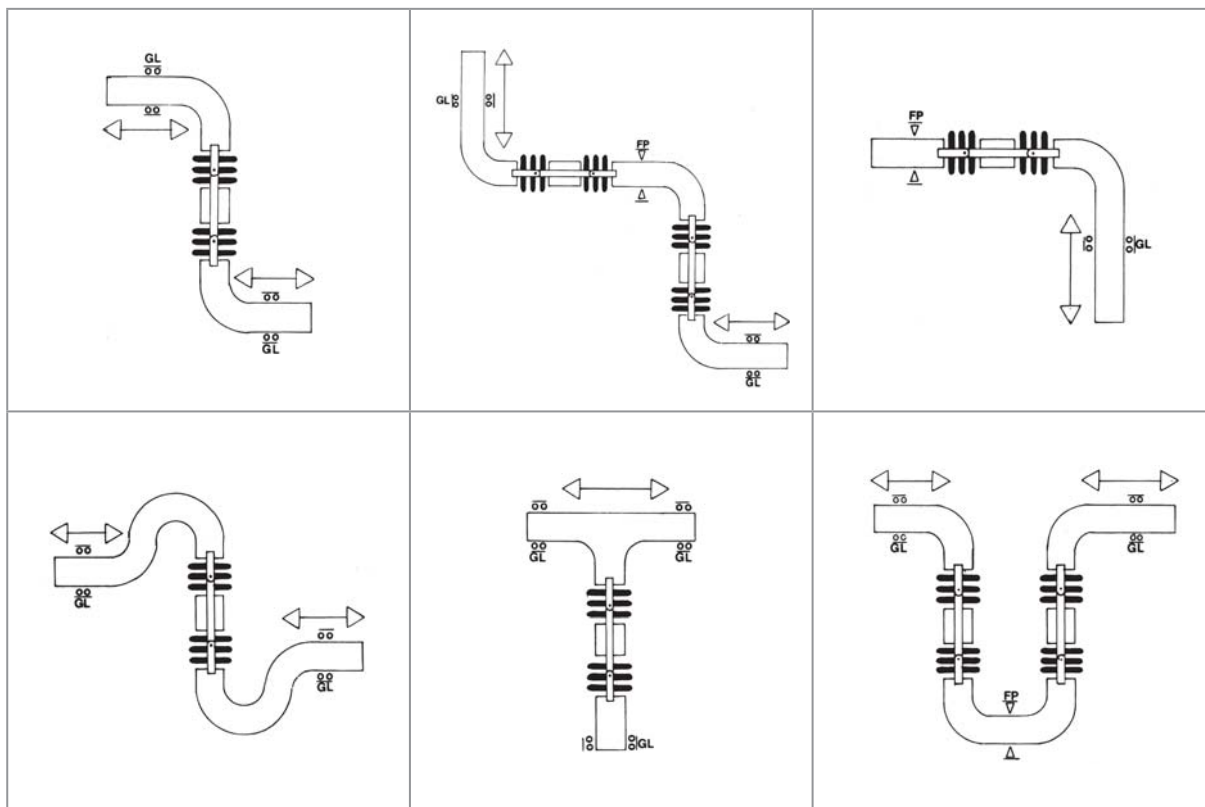

Typical Cases Examples

Lateral expansion joints with tie-rod supports allow lateral movements in a circular plane. Thrusts from the internal pressure are absorbed by the supports, so they might be installed between two intermediate fixed points.

Formation Z-shaped in one plane. Two angular expansion joints or one lateral expansion joint with intermediate pipe.

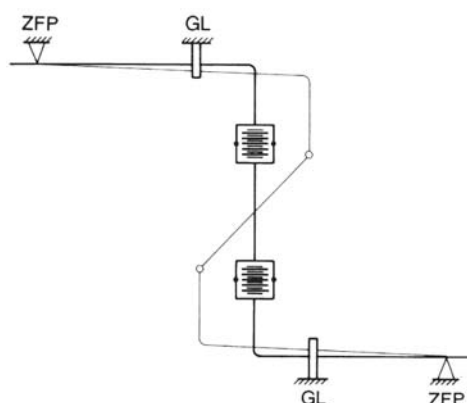

HFP = principal fixed point; ZFP = interm. fixed point; GL = guide.

▶ Angular Expansion Joints

Angular expansion joints exclusively execute angled movements and are therefor always installed as a 2- or 3- joint system. The distance between the joints is decisive for the value of absorption.

Standard type angular expansion joints absorb angled movements in one plane. If angled movements in a circular plane are to be absorbed, cardan expansion joints must be used.

The axial reactional forces are compensated by the joints, so that no heavy demands are made to the conduit and the design of the fixed points. The angular spring rate and the frictional moment of the joints must be considered.

Angular expansion joints are designed according to the operating conditions on site and to your specifications. There is no standard range. Please ask for details.

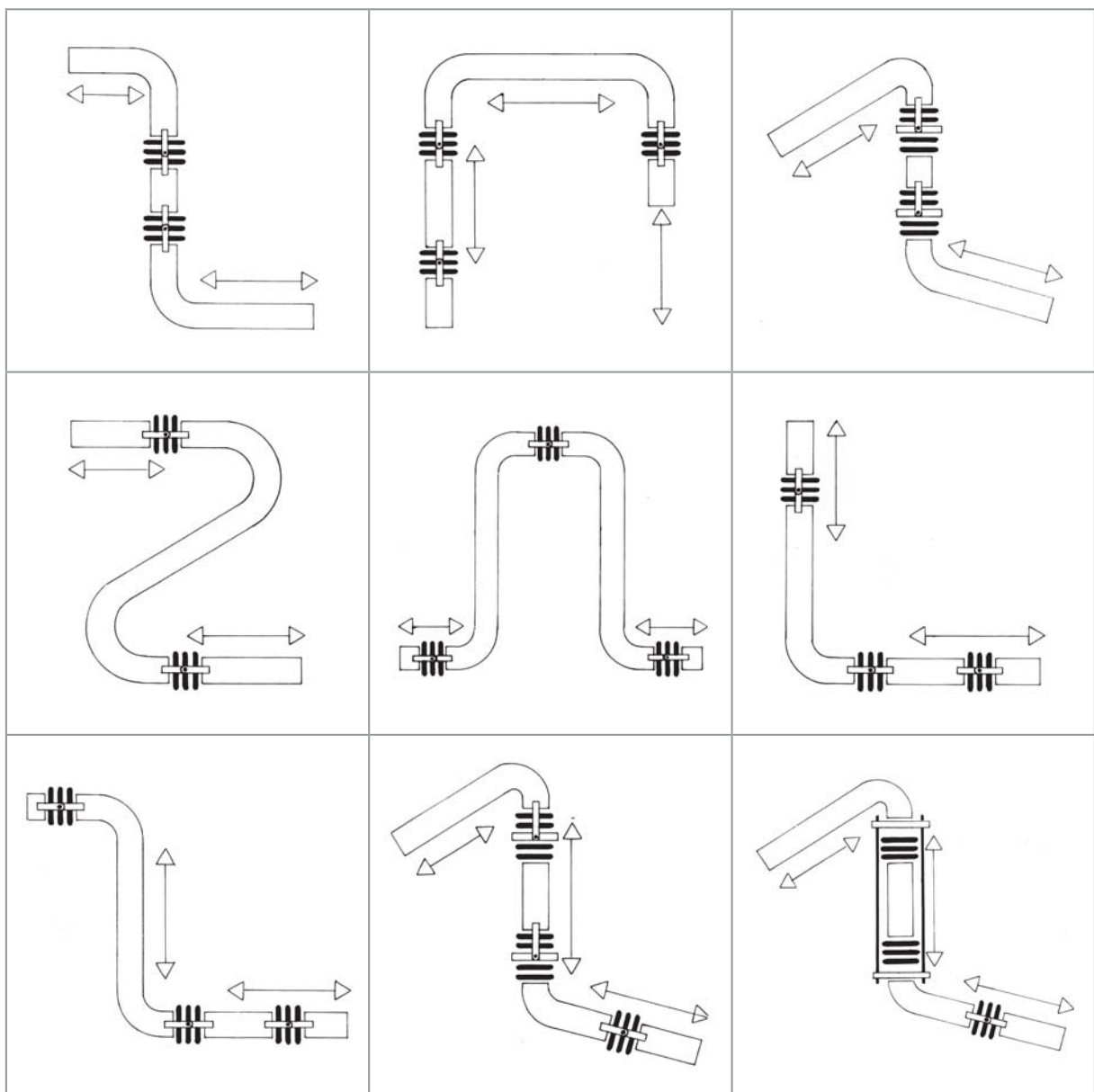

Constructive Types

Angular Expansion Joints are generally based on a single bellows construction restrained with hinged bars or a cardanic system. Available with weld-ends or flanges.

MWP

Angular Expansion Joint
with weld-ends and hinged-bar supports.



MFP

Angular Expansion Joint
with flanges and hinged-bar supports.



Type	Series	Press. thrust restraint	Movements		
			Axial	Lateral	Angular
Single Hinged	MWP MFP	yes	no	Single-Plane	Single-Plane
				no	yes
				Multi-Plane	Multi-Plane
				no	no

MWC

Angular Expansion Joint
with weld-ends and gimbal system



MFC

Angular Expansion Joint
with flanges and gimbal system.



Type	Series	Press. thrust restraint	Movements		
			Axial	Lateral	Angular
Gimbal	MWC MFC	yes	no	Single-Plane	Single-Plane
				no	yes
				Multi-Plane	Multi-Plane
				no	yes

Some applications require compensation for both angular and lateral movements. In these cases special hinged constructions involving two in-line bellows with an intermediate pipe between them are considered the optimal solution. The restraint can be achieved by cardanic system as well.



MWY
Angular-Lateral Double Hinged Expansion Joint with welding ends.



MFY
Angular-Lateral Double Hinged Expansion Joint with flanges.

Type	Series	Press. thrust restraint	Movements		
			Axial	Lateral	Angular
Double Hinged	MWY MFY	yes	no	Single-Plane	Single-Plane
				yes	yes
				Multi-Plane	Multi-Plane
				no	no

Typical Cases Examples

Angular expansion joints are generally used in groups of 2 or 3 and absorb lateral deflections in one or more directions in one plane, whilst one single unit of these joints can only absorb angular movements. Given that these expansion joints themselves bear the internal pressure thrust, they can be fitted between intermediate fixed points. Here are some typical application schemes:

A. Case of angular movement only

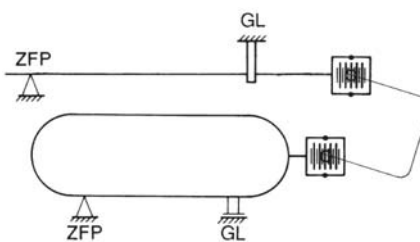

B. Compression in a pipe with angles of up to 90 degrees

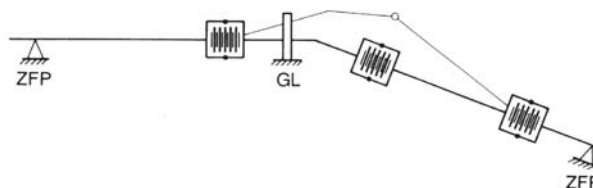

HFP = principal fixed point; ZFP = interm. fixed point; GL = guide.

▶ Special Design Expansion Joints

Rectangular Expansion Joints

MRU

Rectangular Expansion Joint with U-shaped convolutions and round corner.

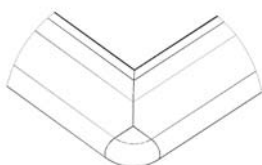

MRV

Rectangular Expansion Joint with V-shaped convolutions and miter corner.

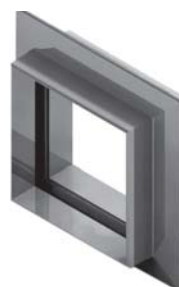
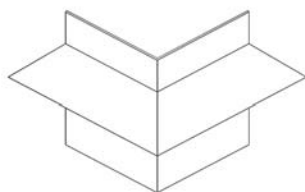

MRW

Rectangular Expansion Joint with V-shaped convolutions and camera corner.

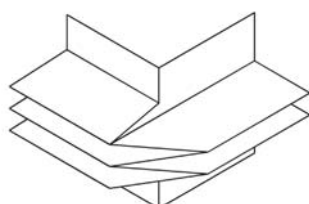

Type	Series	Press. thrust restraint	Movements		
			Axial	Lateral	Angular
Rectangular	MRU MRV MRW	no	yes	Single-Plane	Single-Plane
				yes*	yes*
				Multi-Plane	Multi-Plane
				yes*	yes*

* with limitations.

LENS Expansion Joints

LENS Expansion Joints are characterized by a high convolution profile and thick-ply construction. They can be manufactured in circular, oval or almost any particular shape in various materials.

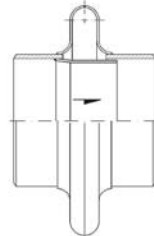

M-LENS

Lens Expansion Joint
with one thick convolution.

Type	Series	Press. thrust restraint	Movements		
			Axial	Lateral	Angular
Lens	M-LENS	no	yes	Single-Plane	Single-Plane
				yes*	yes*
				Multi-Plane	Multi-Plane
				yes*	yes*

Pressure Balanced Expansion Joints

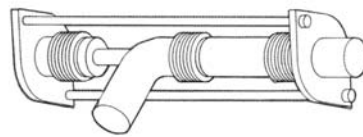

MPB

Pressure Balanced Expansion Joint
with elbow.

Type	Series	Press. thrust restraint	Movements		
			Axial	Lateral	Angular
Elbow Pressure Balanced	MPB	yes	yes	Single-Plane	Single-Plane
				yes	yes*
				Multi-Plane	Multi-Plane
				yes	yes

* with limitations.

Layouts for Pressure Balanced Expansion Joints

Pressure balanced expansion joints have similar applications to axial or lateral types, although they do not transfer the effort due to internal pressure to the pipework.

This characteristic is especially interesting at the union of pipes with turbines or other equipment not able to bear such loads. These joints are always situated where the system changes direction and between intermediate fixed points. It is not necessary to locate them between principal fixed points.

The following are typical examples:

- A. Absorption of axial movements in a straight pipe section, with small deviation.

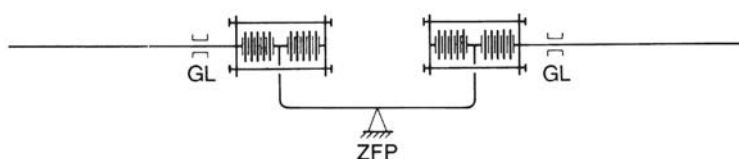

- B. Connection of a turbine. Thrusts from the internal pressure are absorbed by the pressure balanced expansion joint.

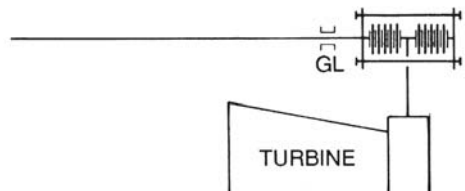

- C. When axial and lateral movements must be absorbed, a 2+1 bellows configuration as shown below is necessary.

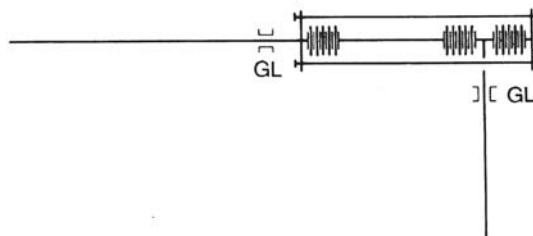

HFP = principal fixed point; ZFP = interm. fixed point; GL = guide.

General Notes on Installation

For their correct function, the expansion joints require some precautions which will prolong their useful life, thus becoming elements virtually free from maintenance.

Most important to bear in mind in the different stages of assembly are described in the following paragraphs.

| Installation

Avoid damaging of the bellows with knocks, strikes, weld splatters, etc. Avoid any movement of the expansion joints with their ends misaligned or beyond the limits established at the time of supply, as regards magnitude of movement or maximum angle.

Presetting are to be carried out in accordance to the established limits, which include direction and magnitude of movement. Expansion joints with inner sleeve must be fitted according to the direction of flow. Transport supports, if any, must be removed after installation.

| Checks Before Putting into Service

Verify that the expansion joints are fitted in the correct place and correctly fitted with respect to the direction of flow. Verify that all transport supports have been removed and any supports and guides are installed according to plan.

Check that there are no misalignments in the expansion joints!

| Checks During and Immediately after Pressure Test

Check if there are any leaks or pressure losses or any instability in the bellows. Also control the firmness of the tie-rods, guides, and any other components of the system.

| Periodical Checks

Verify visually that the expansion joints absorb the movements for which they were designed. Check for unexpected vibrations, signs of external corrosion, looseness of any of the mechanical elements, deterioration of the guides, etc. Verify that there are no accumulations of dust or other particles between the convolutions of the expansion joints which may limit or restrict their movement.

Expansion joints are wear and tear parts. In case of a defect, take precautions and provide for appropriate safety devices.

Fixed Points and Guides

The first step in selecting expansion joints and in the positioning of the fixed points and guides in a pipeline is to divide the pipe into individual lengths having relatively simple configurations (straight lengths, „L”- or „Z”- shapes, etc.) and establish their expansions, since the number of fixed points as well as their position will depend as much on the configurations and dimensions of the expansion joints.

After deciding on the positions of the fixed points, principal fixed points (HFP) and intermediate fixed points (ZFP) must be found. Principal fixed points divide the pipe line into lengths considered individual and whose purpose is to bear the thrust from the internal pressure of the pipe (see loads).

Generally, the principal fixed points are placed:

- At changes of direction in the pipe line;
- Between 2 straight lengths of different sections;
- At valves and other accessories which might be fitted on a straight length;
- At blind pipe ends;
- Anywhere the piping layout requires.

Principal fix points are located at the end of a piping system and must bear high loads. Intermediate fix points either divide two compensation systems in one axis, or support hinged systems. In both cases, the loads are normally rather low.

In the case of L- or Z- shaped lengths, many variables are met within this calculation, such as the type of expansion joint, the different expansions, etc. Our technical department will advise you in each specific case.

Guides

Serve the purpose of supporting the pipework and avoiding misalignments of the expansion. Please find below a typical scheme of positioning of the guides.

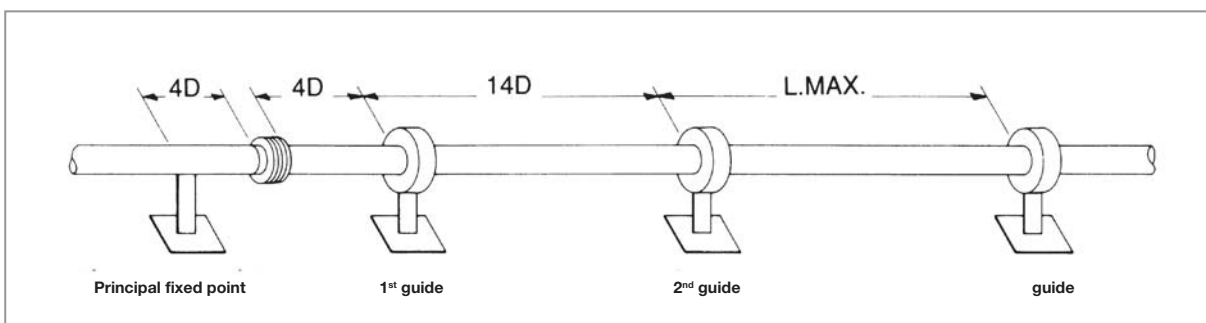

D – diameter of the pipe

Lmax – maximum recommended distance between guides (see diagram on the following page)

Common distances between fixed points are showed in the following diagram. Please note that these values are only a recommendation and may vary from one application to the other.

